

Design of Inverter for BLDC Motor

Shubham V. Nandurkar, Suraj U. Hajare, Vivek S. Rakhade, B. S. Dani, R.P.Argelwar
PCE,Nagpur, India.

Abstract – This paper present a hardware design of voltage source inverter fed BLDC motor. A general overview of BLDC motor, including its advantages over traditional motor is discussed in this paper. Voltage Source Inverter fed brushless DC motor are widely used because of its better performance at low speed. The output drawn by the conventional Diode Rectifier is given to Voltage Source Inverter and by controlling firing of power MOSFET input to BLDC motor can be control. This proposed BLDC motor drive is design to operate at no load and full load speed. Most of the electrical systems today required higher performance on efficiency and lower carbon dioxide consumption. Brushless DC (BLDC) motors can achieve these specifications because the high efficiency in comparison with traditional AC induction motor, and purely powered by electricity.

Index Terms – BLDC Motor, Controller, Diode Bridge Rectifier, Inverter,, Pulse Width Modulation.

1. INTRODUCTION FOR BLDC MOTOR

Brushless DC motors were developed from conventional brushed DC motors with the availability of solid state power semiconductors. Brushless DC motors are similar to AC synchronous motors. The major difference is that synchronous motors develop a sinusoidal back EMF, as compared to a rectangular, or trapezoidal, back EMF for brushless DC motors.

Both have stator created rotating magnetic fields producing torque in a magnetic rotor.

The basic construction of a brushless-dc consists of a fan blade attached to a permanent magnet rotor that surrounds the electromagnetic coils of the stator and associated control electronics.

A typical biphas brushless fan motor is made from a permanent magnet rotor assembly that surrounds four electromagnetic coils. The coils work in pairs, with coils A and C forming one phase and coils B and D the other phase. A Hall effect sensor monitors rotor position, providing feedback to the embedded MCU for commutation, speed regulation, and fault detection.

Conventional dc motors are highly efficient and their characteristics make them suitable for use as servomotors. However, their only drawback is that they need a commutator and brushes which are subject to wear and require maintenance. When the functions of commutator and brushes were implemented by solid-state switches, maintenance-free motors

were realized. These motors are now known as brushless dc motors.

Brushless dc motor have become increasing popular in past decade due to advantages such as high efficiency, high power density , compact size ,high ruggedness, low maintenance requirement. recent trends, energy efficiency has become an important aspect of an electrical drive system due to the scarcity of the energy resources. The selection of a motor for a particular drive application is a foremost task and it depends on variety of parameters such as high efficiency, compact size and good performance over a wide range of speed control.

This motor possess many advantages such as compact size, high energy density, high efficiency, silent operation, highly rugged construction, low electro-magnetic interference (EMI) problems and requires very less maintenance .The problems related to mechanical commutator and brushes assembly such as sparking, noise and EMI issues are eliminated in BLDC motor.

2. PROPOSED CONTROL SCHEME

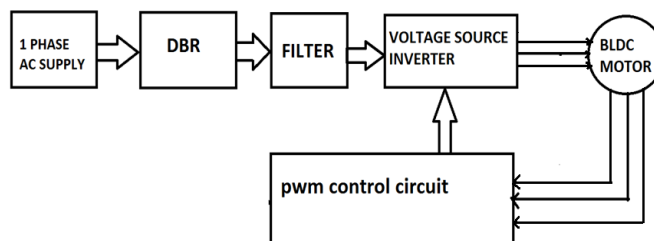

BLOCK DIAGRAM OF DESIGN OF INVERTER FOR BLDC MOTOR

This paper gives the design of voltage source inverter for speed control of BLDC motor .In this single phase supply is given to ' Diode Bridge Rectifier (DBR) ' .which converts the AC supply to DC supply. But this DC supply contains ripple components in it. this ripple is removed with the help of filter. Hence filter is connected in this circuit to obtain the ripple free DC supply. This ripple free DC supply is given to the voltage source inverter which converts DC supply to AC supply.

The voltage source inverter contains six switches to drive 3-phase BLDC. The designated order 1 to 6 represents the sequence of switch operation in time. It contains of 3 phase legs which operate in 120° apart. The three phase legs have a phase shift at 120° among themselves that means phase leg (3-6)

switches 120° after phase leg (1-4) and phase leg (5-2) switches 120° after (3-6). Switch 1 and 4 get turned ON to give the voltage at one phase i.e., V_a . Switch 3 and 6 turned ON to give voltage V_b .

Switch 5 and 2 turned ON to give voltage V_c . From voltage source inverter converts DC supply to AC supply. AC supply is given to the BLDC to start the motor.

3. DIODE BRIDGE RECTIFIER

Diode Bridge Rectifier consist of four diode which can be used to convert dc supply and which are connected in anti-parallel manner. In this single phase supply is given to ' Diode Bridge Rectifier (DBR).which converts the AC supply to DC supply. Rectified supply is pass to the inverter through the Filter circuit. DC supply contains ripple components in it. this ripple is removed with the help of filter. Capacitor has the property to block the AC components hence Capacitor is used to remove ripple component. It can be cheapest way to remove the ripple component . Hence filter is connected in this circuit to obtain the ripple free DC supply. This ripple free DC supply is given to the voltage source inverter which converts DC supply to AC supply.

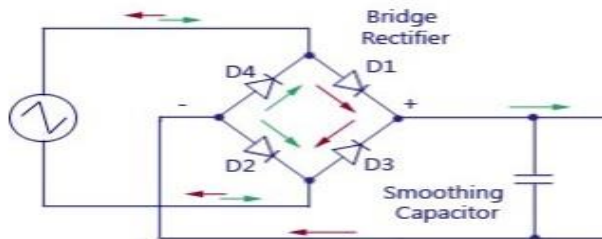

4. CONTROL CIRCUIT FOR INVERTER

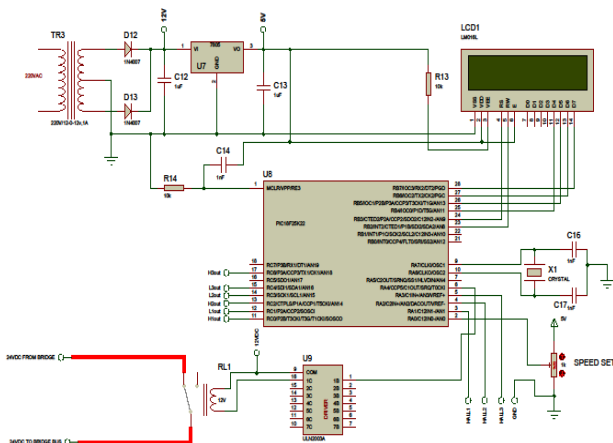

The function of control circuit is to generate the pulses for the switches which is connected in the inverter circuit for TURN ON the Switches. The pulses is generated by the PWM technique. Thus in this we can generate the pulses by micro-controller . In it we can programmed the micro-controller and generate the pulses for TURN ON te switches. The control circuit is consist of micro-controller IC, regulator IC,crystal, oscillator, capacitors, LCD etc. We can use the micro-controller PIC18F25K20. It is a three port and 28 pins IC.

The voltage required for the IC is 5 volt which can be taken bye the regulator IC(7805) .Which can be convert the 12 volt supply into 5 volt for its operation. This supply is given to the micro-controller IC through the pin-1 . and same supply is given to the LCD for its operation. LCD is a 16 character -2 layer alpha-numeric LCD. LCD are connected to micro-controller through 25, 26, 27, 28 pin. Crystal oscillator is connected across the pin no. 9 and 10 to set the frequency of the controller. Two capacitor are connected across the oscillator to maintain the duty cycle of the switches. We can use the driver IC(ULN2003A) for converting the 5 volt to 12 volt for the operation of relay. Pin no. 11, 12, 13, 14, 15, 17 are gives the pulses for the switches to TURN ON it.

5. DRIVER CIRCUIT FOR INVERTER

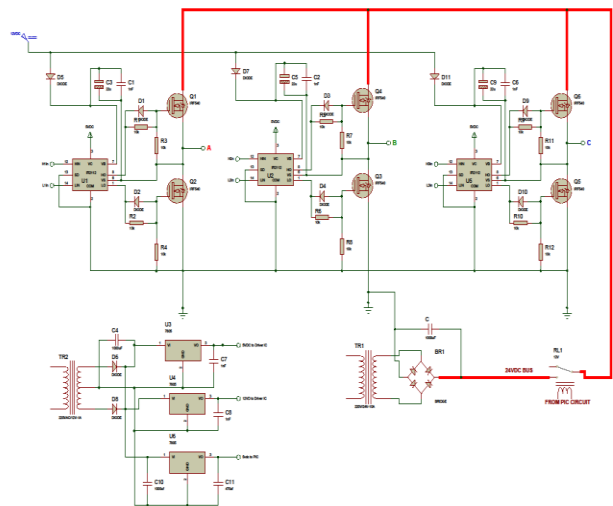

The driver circuit it can be separate the part of inverter and control circuit. The driver circuit is consist of driver IC(IR2112) of 14 pin. For three phase inverter three driver IC are needed which can be supplied by 5 volt supply for its operation through pin no. 3. The pulses are generated by control circuit are given to the switches through the driver IC pin no. 12 and 14. Electrolytic capacitor in parallel with ceramic capacitor is use as a boost trapping capacitor. High switch are connected to pin no. 6 and 8. Low switch are connected to pin no. 1. Diode and resistance are use for protection of from reversal of supply from switches. Pin no. 2

and 13 are shorted and are connected to the ground. This driver design are three same manner for three leg of inverter. Two different Regulator IC are use which convert the 12 volt to 5 volt and 12 volt To Driver IC.

The transformer of 220v/24v-10A which step down the supply. And convert it into DC supply by the Diode Bridge Rectifier. it connected to the terminal of switch through the Relay (12 V).

6. HARDWARE DESIGN OF CONTROL CIRCUIT

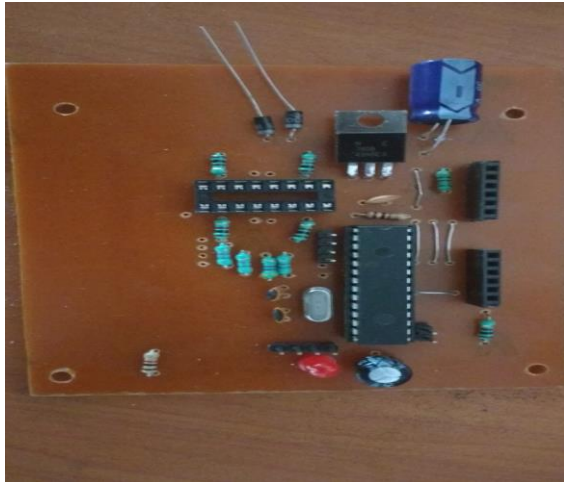

7. HARDWARE DESIGN OF DRIVER CIRCUIT

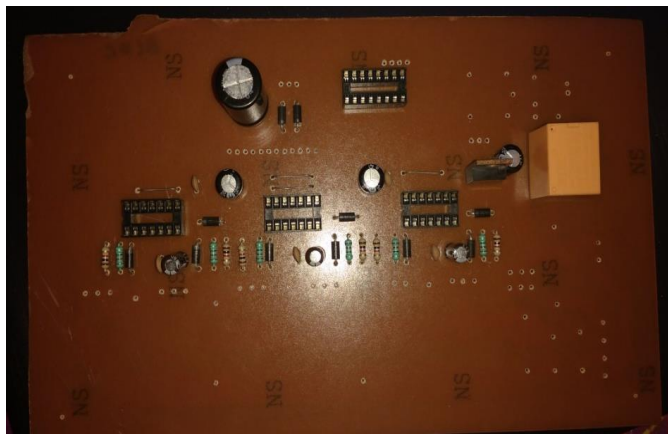

8. RESULT

The result of pulse generation of control circuit for gate terminal of switch is verified on the CRO.

REFERENCES

- [1] M.S Aspalli and Savitri I. Medegar "Speed Control Of BLDC Motor With Three Phase Inverter Using Signal Controller", In Conf. of IEEE, DOI:-10.1109/1CPACE, Sep 2015.
- [2] K.B Laresen and L. Helle "Analysis Of Symmetrical Pulse Width Modulation Strategies For Matrix Converter", In Conf. IEEE Paper Doi:10.1109/Psec.2002, June 2002
- [3] T.J Sokira and W. Jaffe, "Brushless DC motor, Electronic Communication and Control", in conf. IEEE Paper, Tabs Books, 1989.
- [4] S.B Ozturk and H.A Toliyat "Analysis of Brushless DC Motor Control And Hall Sensor", In Conf. IEEE Paper, Rec. 42nd IAS Annu. Meeting Sep 2009.
- [5] Professor Stephen J. Bitar, " Analysis Of Pwm Techniquenic: A Pure Sin Wave And Symmetrical Multiple Pulse Width Modulation", In Conf. IEE Paper ,Vol. 142 , Jul 1998.
- [6] A. Moon, B. S. Dani and R. Argelwar, "Analysis of boost converter and interleaved converter for permanent magnet synchronous motor of Hybrid electrical vehicle," *2016 International Conference on Electrical, Electronics, and Optimization Techniques (ICEEOT)*, Chennai, 2016, pp. 4298-4303.
- [7] A. Dodke, R. Argelwar, B. S. Dani and S. P. Muley, "Comparison of cuk and buck converter fed electronically commuted motor drive," *2016 International Conference on Electrical, Electronics, and Optimization Techniques (ICEEOT)*, Chennai, 2016, pp. 4292-4297.
- [8] M.S Aspalli and Savitri I. Medegar "Speed Control Of BLDC Motor With Three Phase Inverter Using Signal Controller", In Conf. of IEEE, DOI:-10.1109/1CPACE, Sep 2015.
- [9] K.B Laresen and L. Helle "Analysis Of Symmetrical Pulse Width Modulation Strategies For Matrix Converter", In Conf. IEEE Paper Doi:-10.1109/Psec.2002, June 2002
- [10] T.J Sokira and W. Jaffe, "Brushless DC motor, Electronic Communication and Control", in conf. IEEE Paper, Tabs Books, 1989.
- [11] S.B Ozturk and H.A Toliyat "Analysis of Brushless DC Motor Control And Hall Sensor", In Conf. IEEE Paper, Rec. 42nd IAS Annu. Meeting Sep 2009.
- [12] Professor Stephen J. Bitar, " Analysis Of Pwm Techniquenic: A Pure Sin Wave And Symmetrical Multiple Pulse Width Modulation", In Conf. IEE Paper ,Vol. 142 , Jul 1998.
- [13] Rahul P. Argelwar, V. S. Nandanwar, Sapna Verma, "PFC Zeta Converter Fed BLDC Motor Drive for Fan Applications", *International Journal of Research in Advent Technolgy*, Vol.2, No.2, February 2014 E-ISSN: 2321-9637
- [14] Rahul P. Argelwar, V. S. Nandanwar, Sapna Verma, "Speed Control of Zeta Converter Fed BLDC Motor Drive", *International Journal of Electrical Electronics & Computer Science Engineering* Volume 1, Issue 6 (December 2014), ISSN : 2348 2273, pp.63-66